

**TIMKEN****The Timken Company**

4500 Mt Pleasant St. NW

N. Canton, OH 44720

Phone: (234) 262-3000

E-Mail: [CustomerCAD@timken.com](mailto:CustomerCAD@timken.com) • Web site: [www.timken.com](http://www.timken.com)

Part Number 3210 AJ/2RS, Timken® Double Row Angular Contact Ball Bearings (3200, 3300)

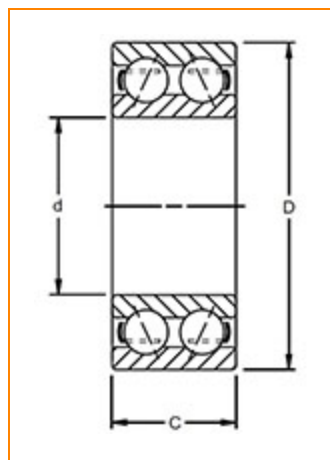

[Dimensions](#) | [Specifications](#) | [Basic Load Ratings](#) | [Abutment and Fillet Dimensions](#)

## Dimensions

|                    |                       |
|--------------------|-----------------------|
| d - Bore           | 50.00 mm<br>1.9685 in |
| D - Outer Diameter | 90.00 mm<br>3.5433 in |
| C - Ring Width     | 30.2 mm<br>1.1890 in  |
| Contact Angle      | 30 °                  |

## Specifications

|           |               |
|-----------|---------------|
| Features  | Contact Seals |
| Ball Type | STEEL         |



|                |                     |
|----------------|---------------------|
| Cage Type      | Pressed             |
| Cage Material  | Steel               |
| Bearing Weight | 0.70 Kg<br>1.550 lb |
| Design Units   | METRIC              |

### Basic Load Ratings

|                                |                     |
|--------------------------------|---------------------|
| C0 - Static Radial Rating      | 39900 N<br>8968 lbf |
| C1 ISO - Dynamic Radial Rating | 43900 N<br>9867 lbf |

### Abutment and Fillet Dimensions

|   |                     |
|---|---------------------|
| R - Inner Ring "To Clear" Radius <sup>1</sup> | 1.10 mm<br>0.043 in |
| r - Outer Ring "To Clear" Radius <sup>2</sup> | 1.10 mm<br>0.043 in |
| da - Inner Ring Backing Diameter              | 57.0 mm<br>2.244 in |
| Da - Outer Ring Backing Diameter              | 83.0 mm<br>3.268 in |

<sup>1</sup> Maximum housing fillet radius that bearing corners will clear.

<sup>2</sup> Maximum shaft fillet radius that bearing corners will clear.

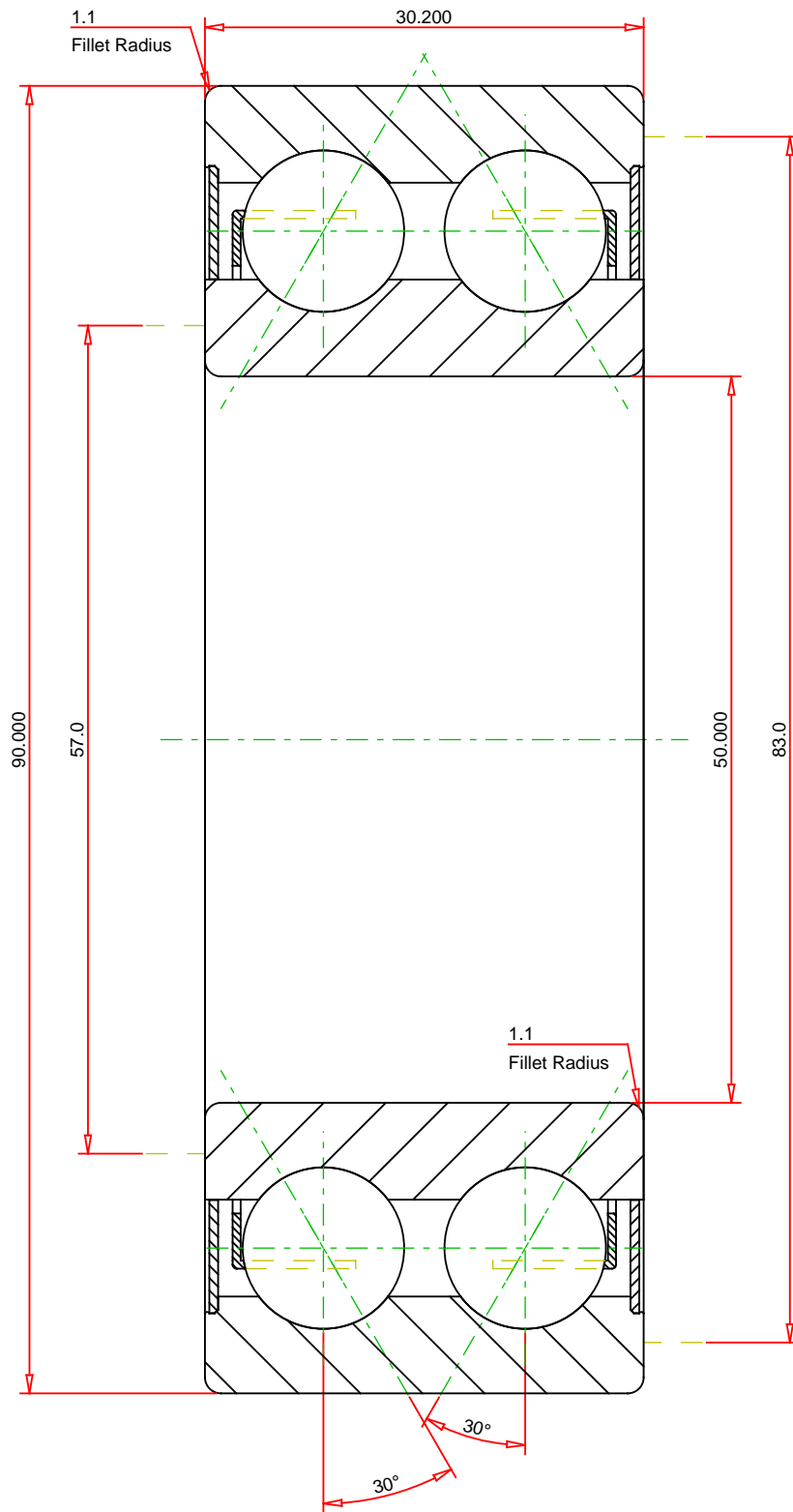

**METRIC UNITS**

Number of Balls Per Row 22  
 Bearing Weight 0.700 kg

**TIMKEN**®

**3210 AJ/2RS**  
 Timken® Double Row Angular Contact Ball Bearings  
 (3200, 3300)

**THE TIMKEN COMPANY**  
 NORTH CANTON, OHIO USA

Dynamic Load Rating 43900 N  
 Static Load Rating 39900 N

Every reasonable effort has been made to ensure the accuracy of the information contained in this writing, but no liability is accepted for errors, omissions or for any other reason.

**FOR DISCUSSION ONLY**